



FABRYKA MIESZALNIKÓW INA





The mission of the Mixer Factory – INA is to create and deliver the best solutions for the specialised transport of concrete mixes. The company's activities are based on core values such as people, innovation, quality and safety. For the Mixer Factory – INA the most important thing is to build the company as a reliable and credible supplier.

The Mixer Factory – INA has been operating since 2012.



We specialise in the manufacture of innovative mixers for hydraulic concrete mixer trucks.

Our range is complemented by spare parts and components for concrete mixers.



All offered products comply with the current standards and are manufactured with the utmost care. The Factory's products are designed to serve users for many years.



We provide high-quality services, innovative technical solutions, expert advice and efficient installation of mixers and components.

WE ARE LOOKING FORWARD TO DOING BUSINESS WITH YOU

Durability and quality

Thanks to a solution developed and patented by our research and development team, the service life of the mixer drum is significantly extended. At the Customer's request, we manufacture mixers from the most robust abrasion-resistant steels. This extends the life of the drum even under the harshest operating conditions.



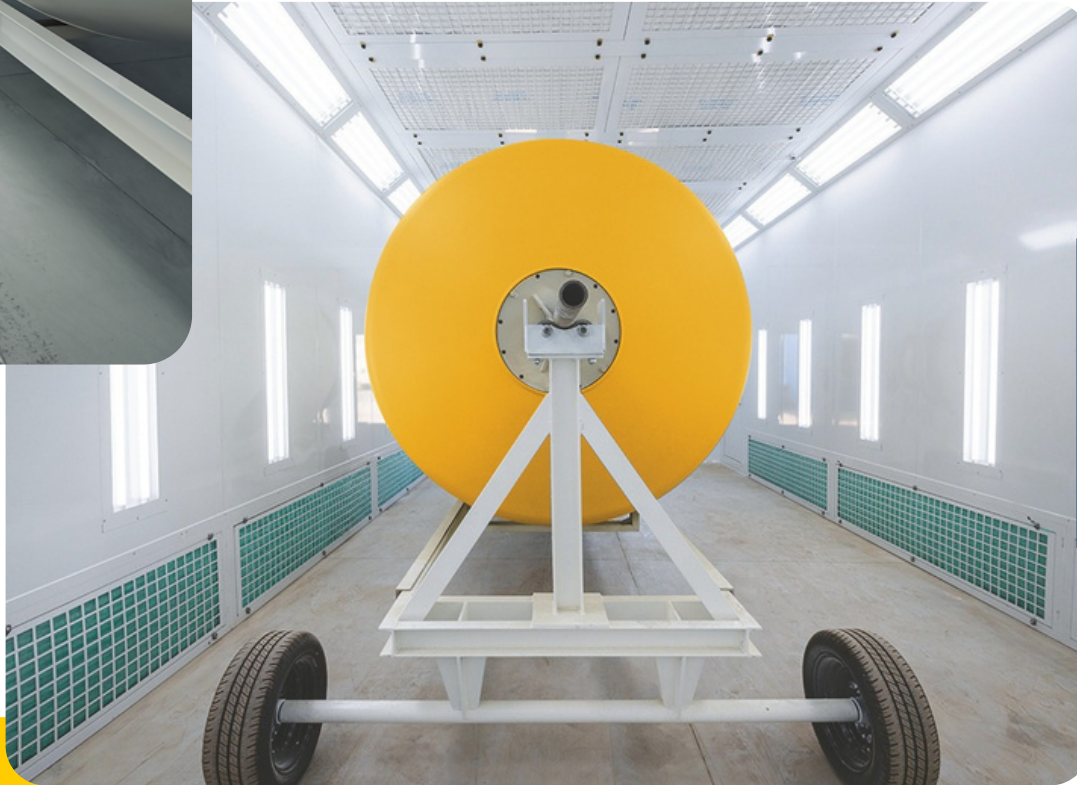



We offer a comprehensive service for the supply and start-up of mixers at the Customer's site.



We provide professional warranty and post-warranty service. Specialists in our Service Department deal with repairs of mixers and their parts.



The choice of equipment that transports concrete from the concrete plant to the construction site often determines whether construction projects will be successfully completed.

As with all technical equipment, concrete mixers are subject to wear and tear as a result of their operation – we provide concrete mixer overhaul services.

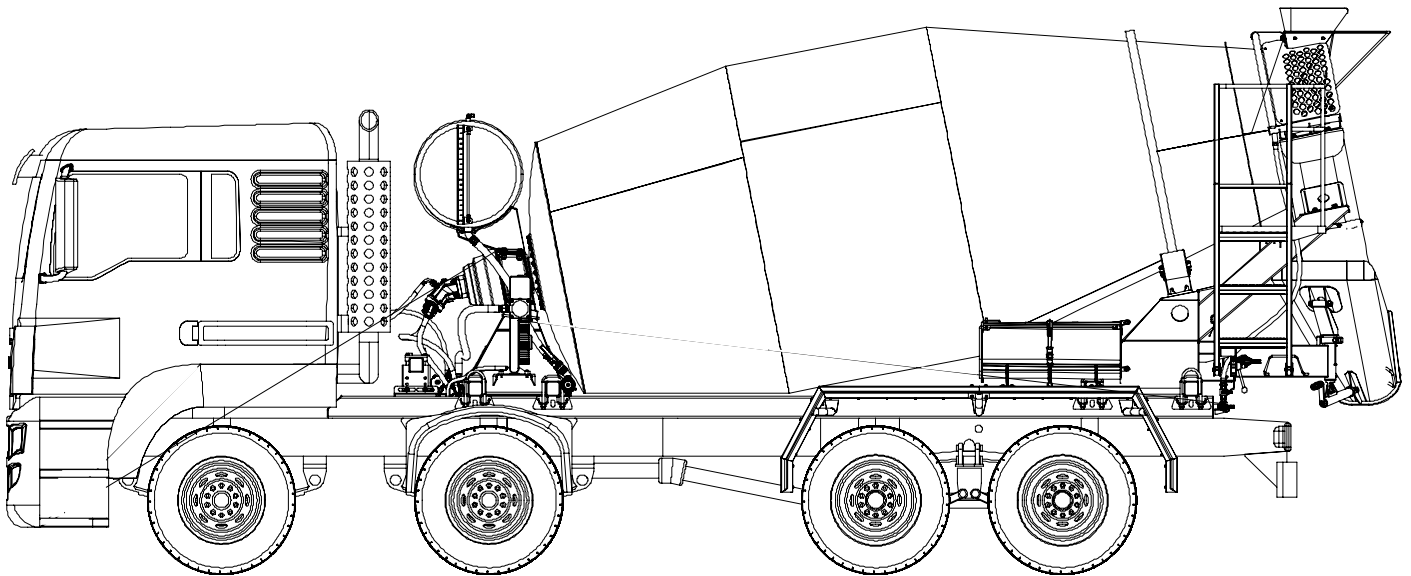

We offer mixers for hydraulic concrete mixer trucks with capacities tailored to the Customer's needs.



To ensure that the concrete maintains all its properties, one of the most important stages is transport in a suitably adapted mixer of a concrete mixer truck.

Our mixers guarantee complete reliability and cost-effectiveness of transport. The technical qualities on the basis of which the mixers were developed and manufactured make it possible to maintain the concrete specifications during delivery from a mixing plant to a construction site.

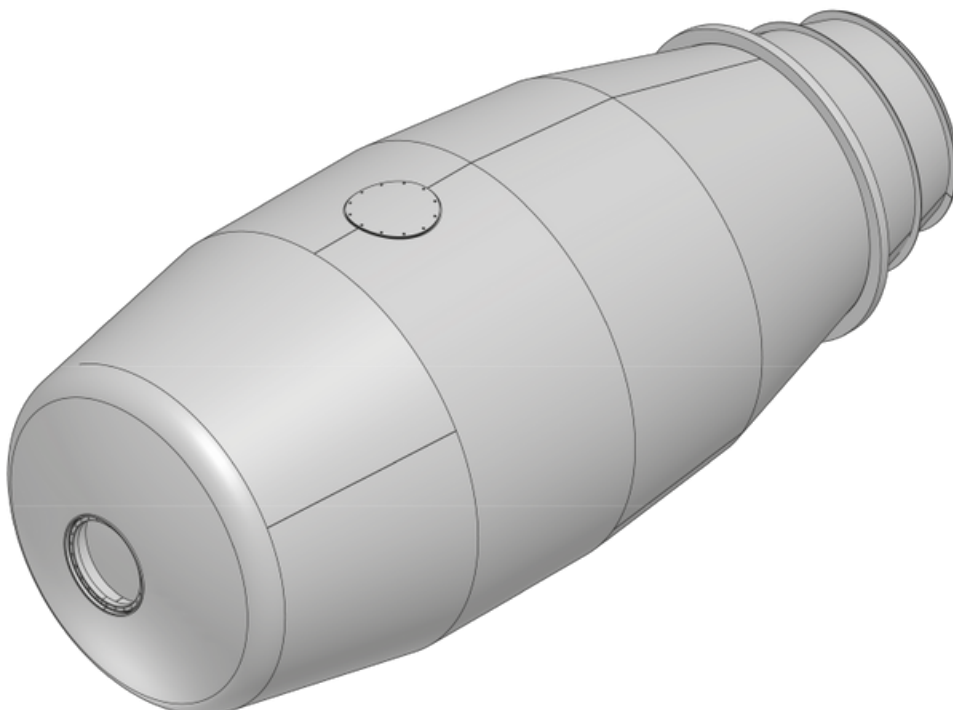
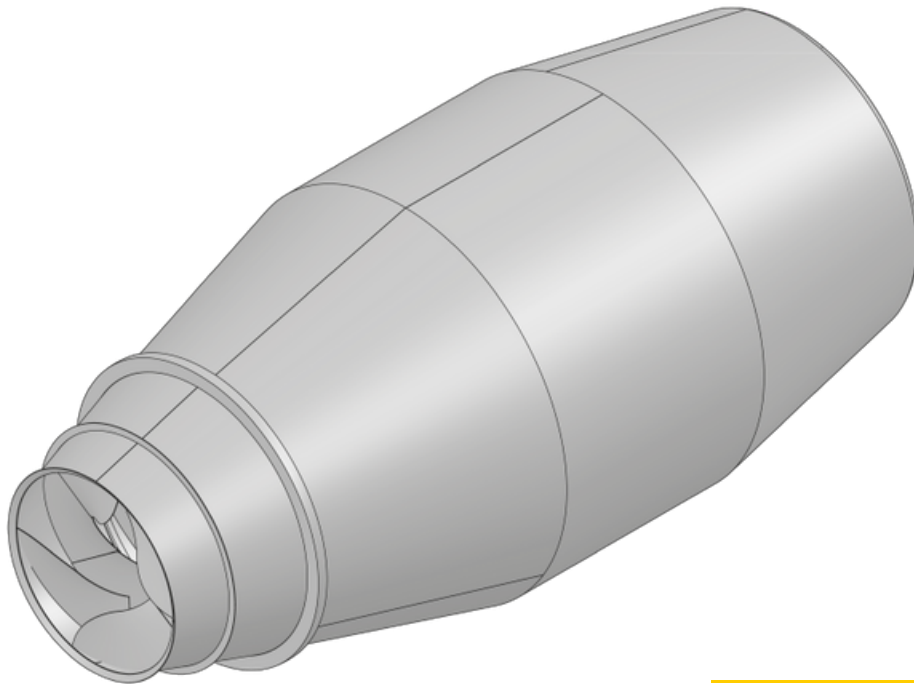

Our engineers and specialists take on new challenges and their work results in innovative and patented design solutions.

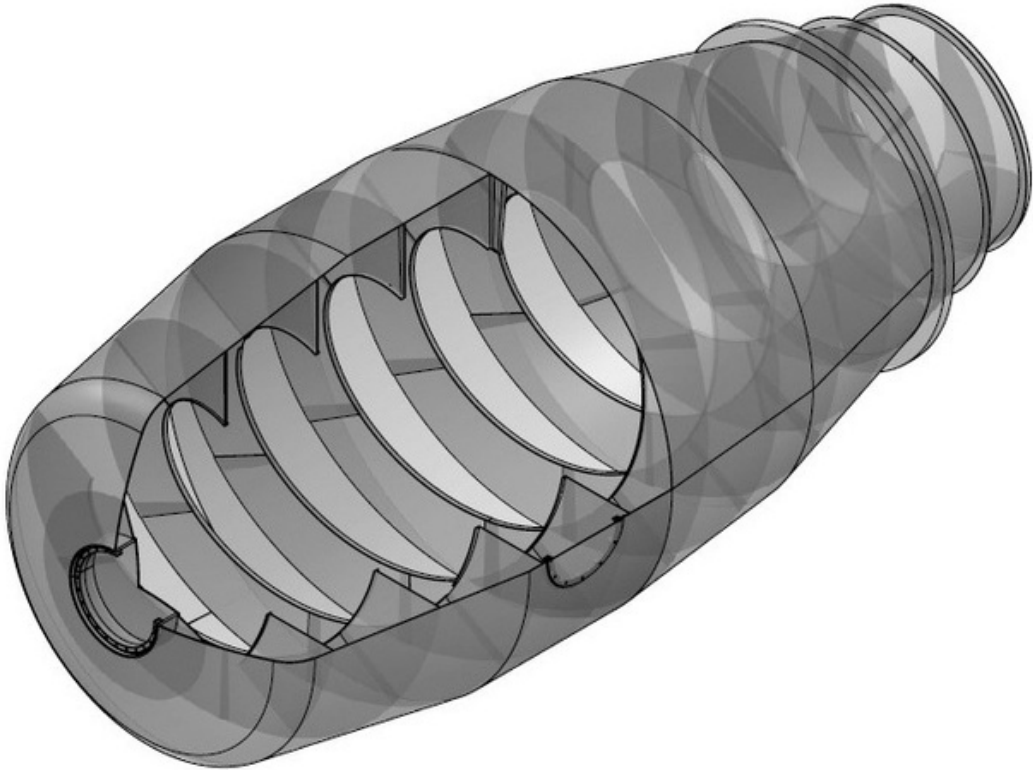

In order to meet the market expectations, we have implemented improvements by optimising the geometry of the mixer drum.

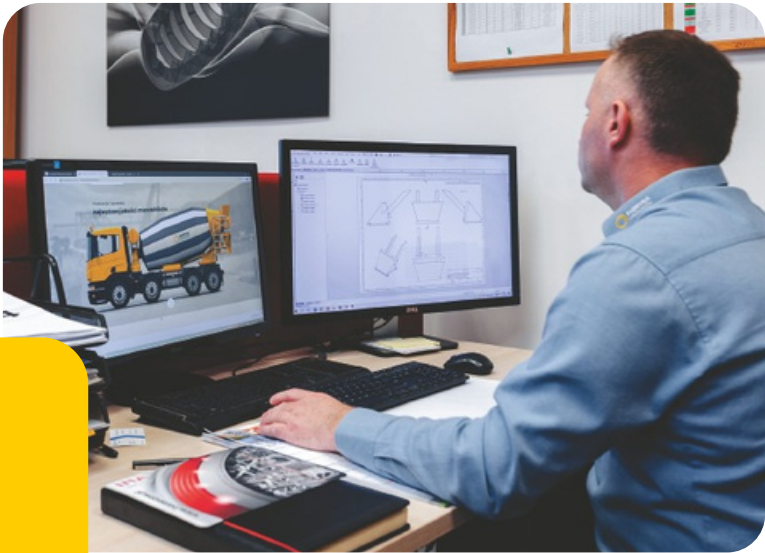
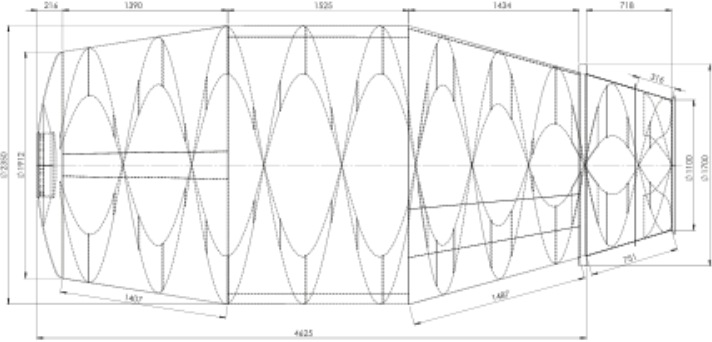

The unique design and the proper shape of the mixing and discharging spiral blades guarantee homogeneity of the concrete mix in all sections of the mixer drum.

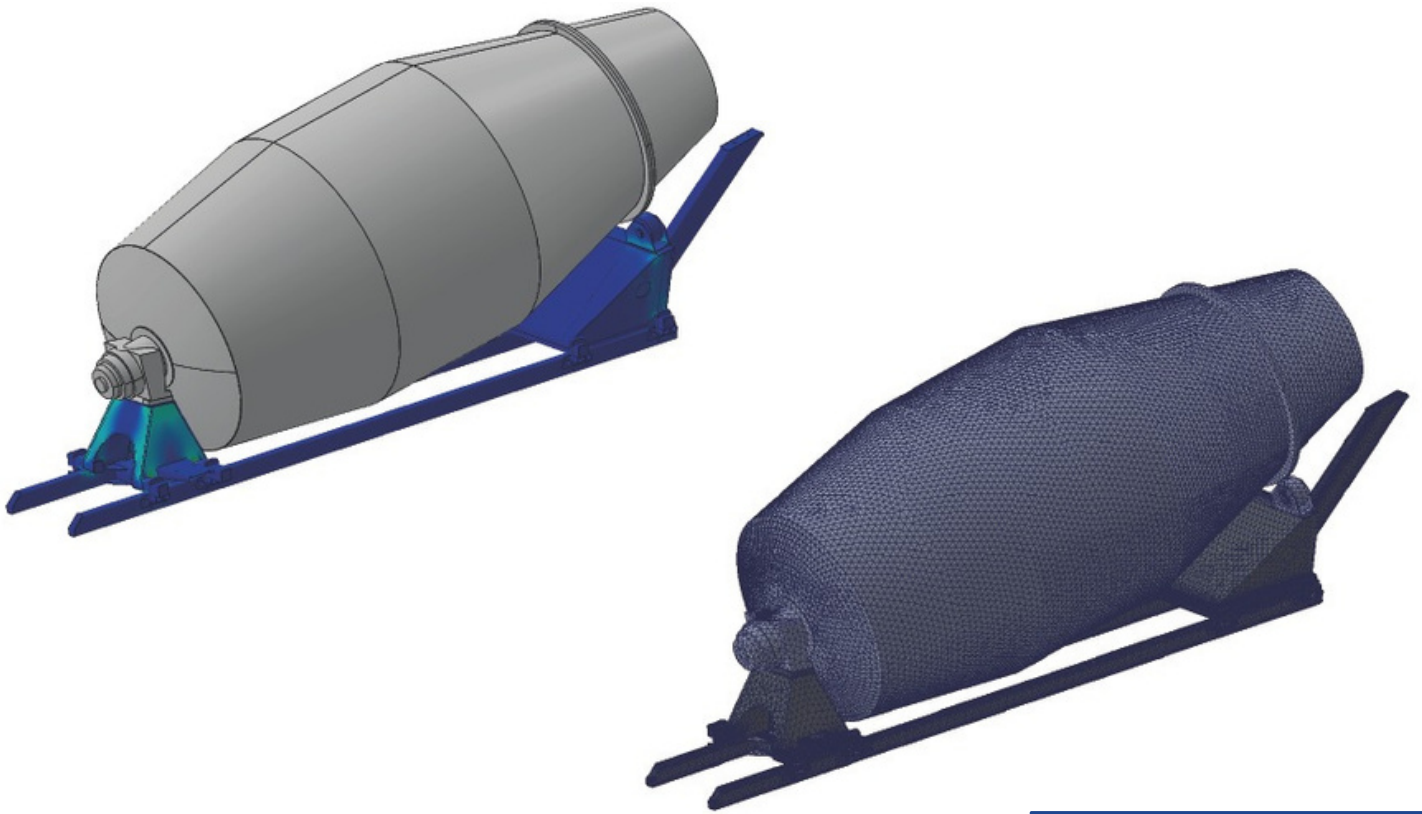

We have our own construction and design department. Our team of specialists carries out research and development work so that we can implement innovative and patented design solutions.

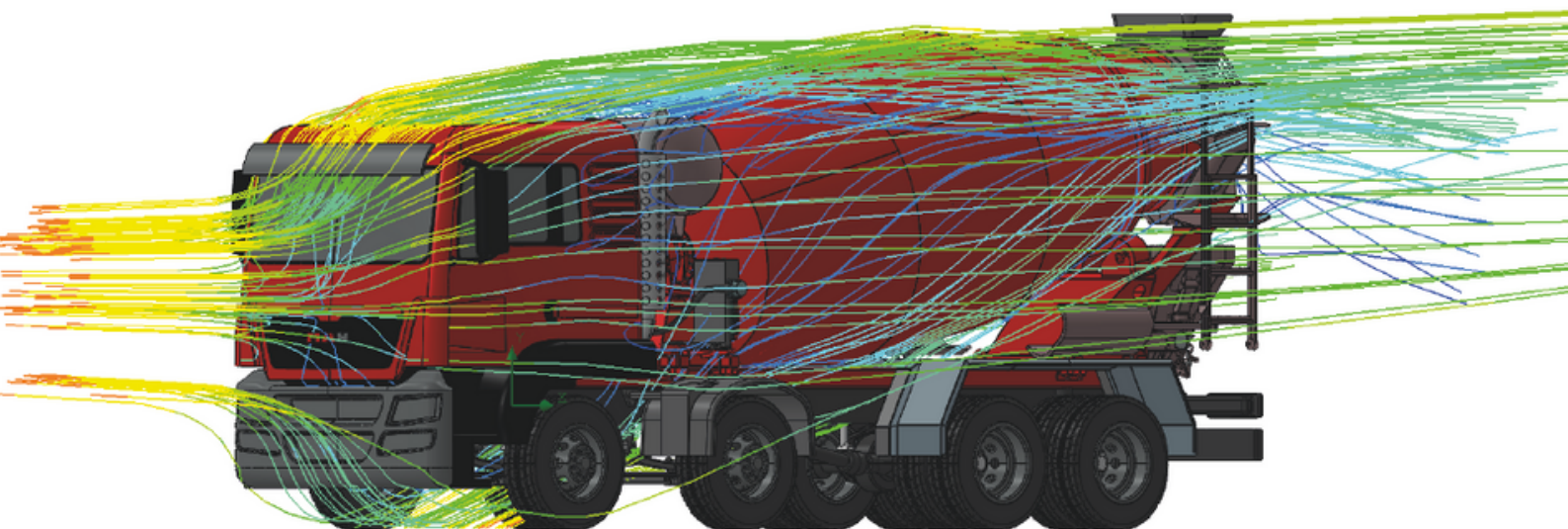

The Mixer Factory – INA sells top-quality components and spare parts for concrete mixer trucks. All products are manufactured with the same care and precision as the originals and are subject to the same quality control requirements.

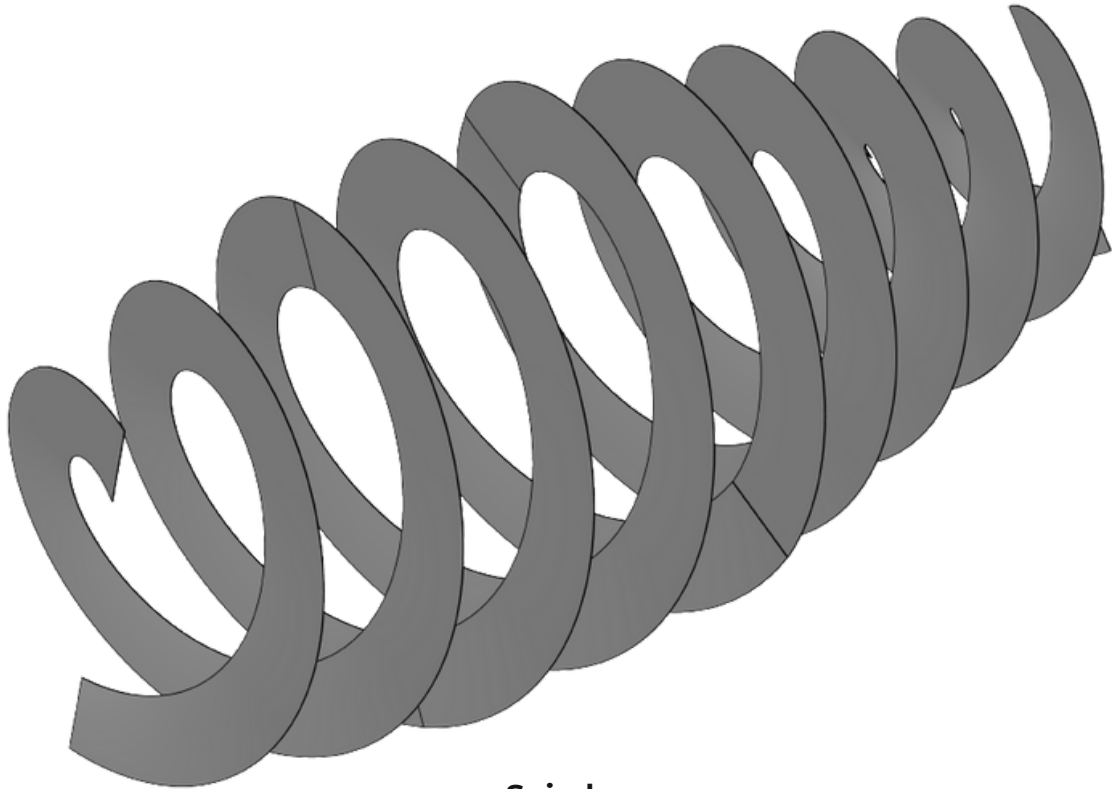

Spiral



Filters



Friction sheet metal



Rolls



Extension chutes

Assembly and disassembly are complex operations that require specialised equipment and experienced staff.

We make deliveries throughout Europe.

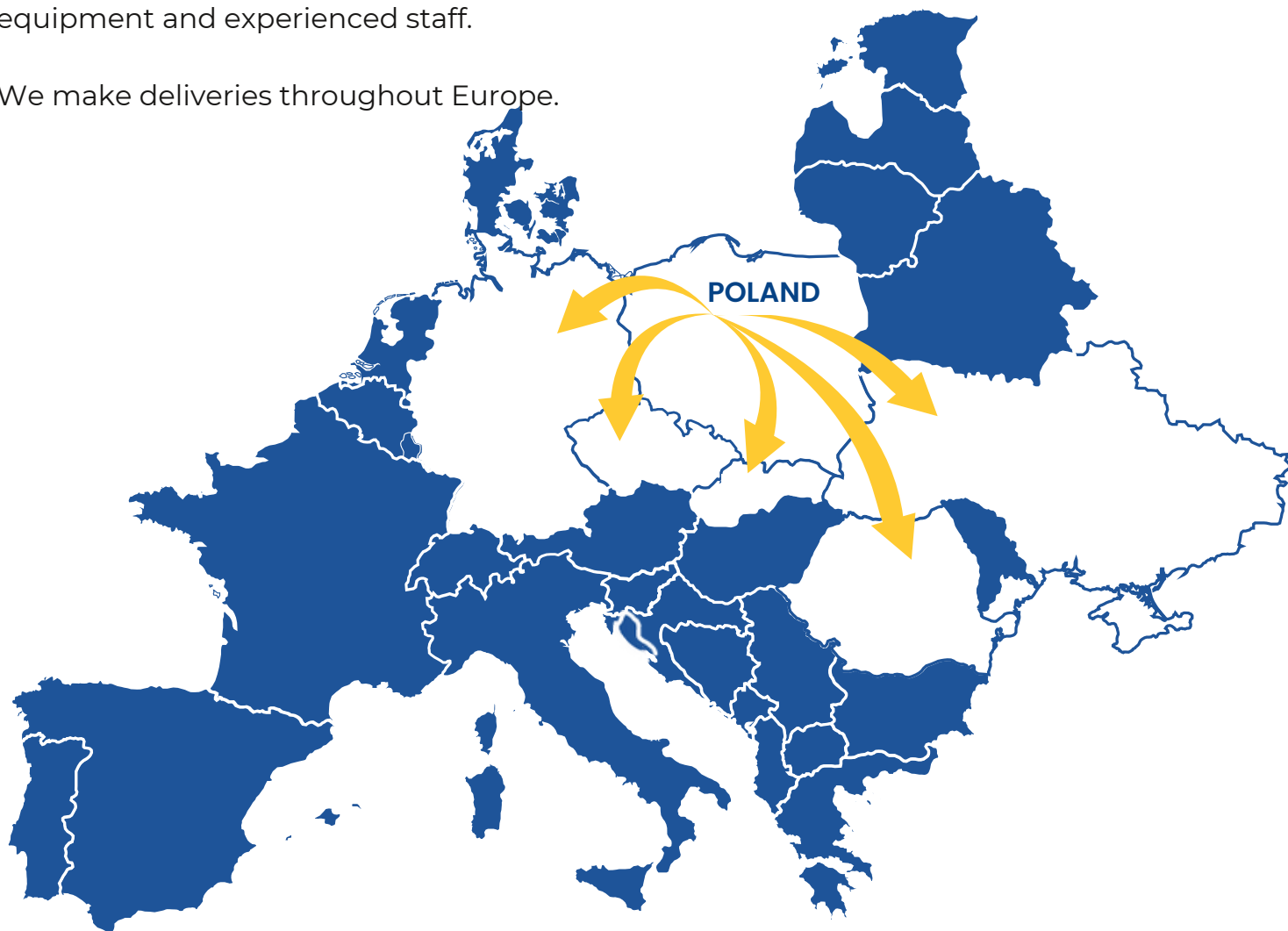



WE WILL DELIVER YOUR ORDER TO THE ADDRESS OF YOUR CHOICE











Fabryka Mieszalników - INA Sp. z o.o.

 +48 887 810 900
+48 695 780 880

 biuro@fabrykamieszalnikow.pl

 www.fabrykamieszalnikow.pl



 **Manufacturing plant:**
ul. Tadeusza Boya-Żeleńskiego 11
35 -105 Rzeszów / Poland

